



Chicago Southland's Green TIME Zone: (Green Transit, Intermodal, Manufacturing Environment Zone)



A Core Element of the Southland Vision 2020 for Sustainable Development

Southland Vision 2020: Green TIME Zone Strategic Overview

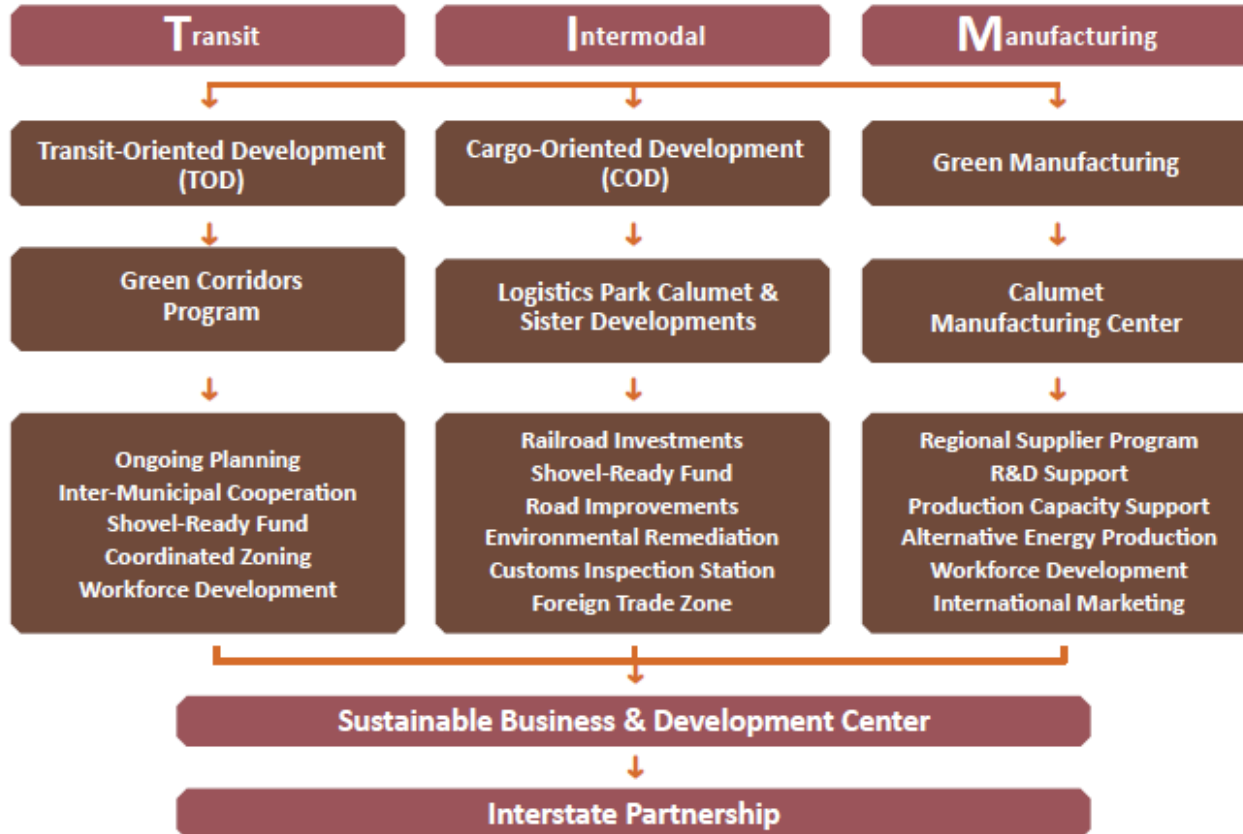

Transit-Oriented Development (TOD)



Much TOD Planning Completed or Underway

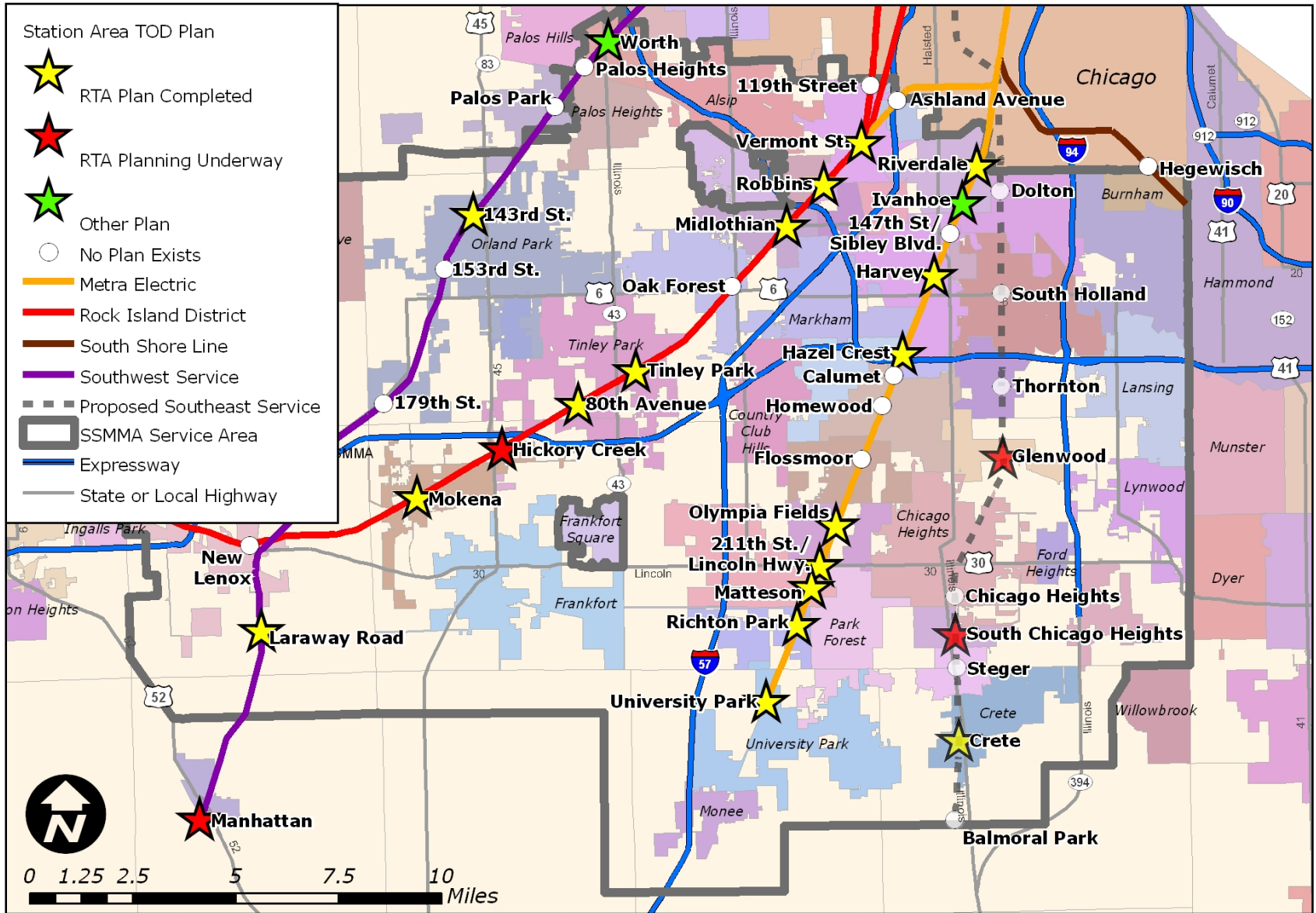

Neighborhood Stabilization Program Focus on TOD



Complementary TOD and COD Corridors

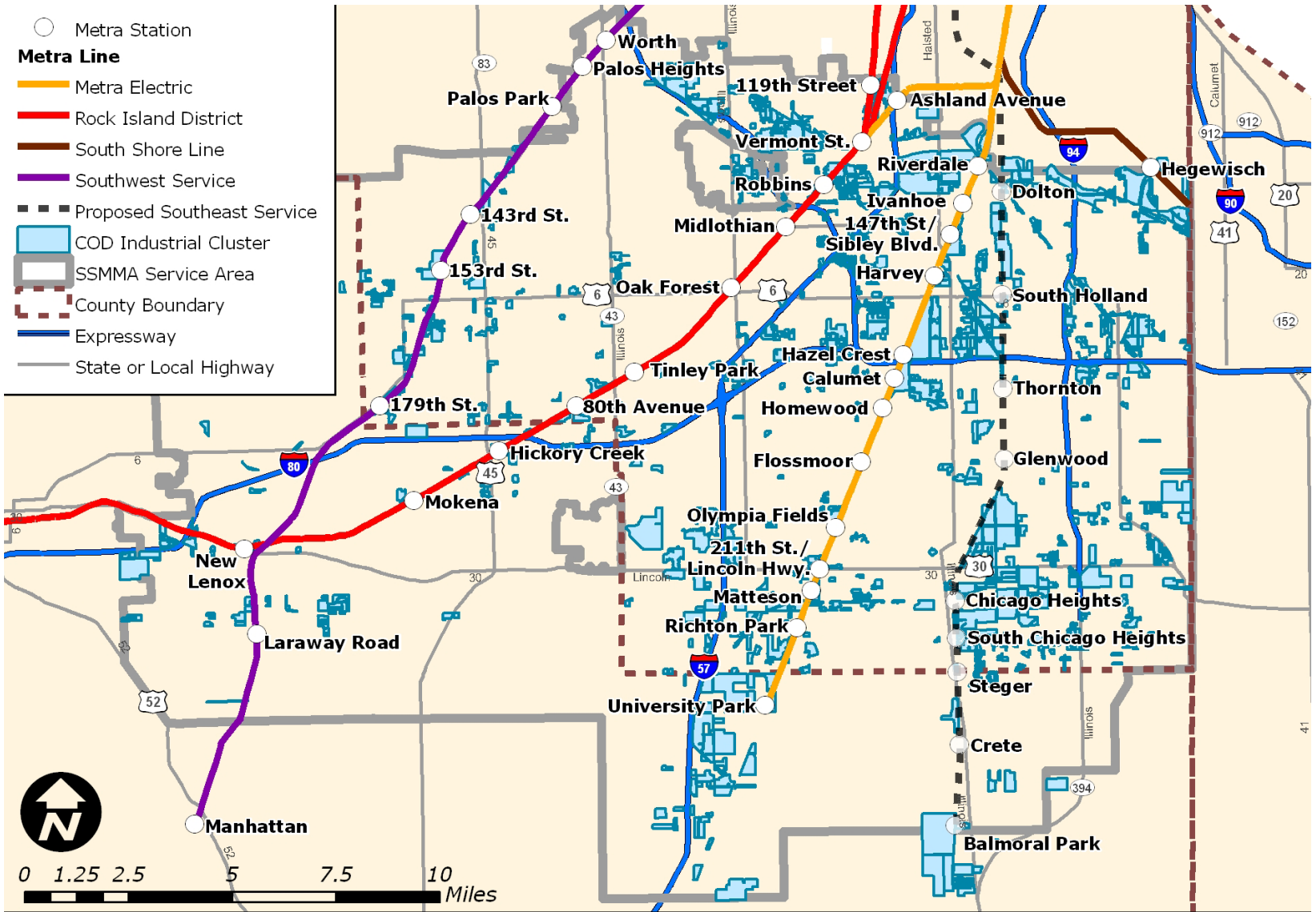

Cargo-Oriented Development (COD)



Freight Facilities are Major Job Anchors

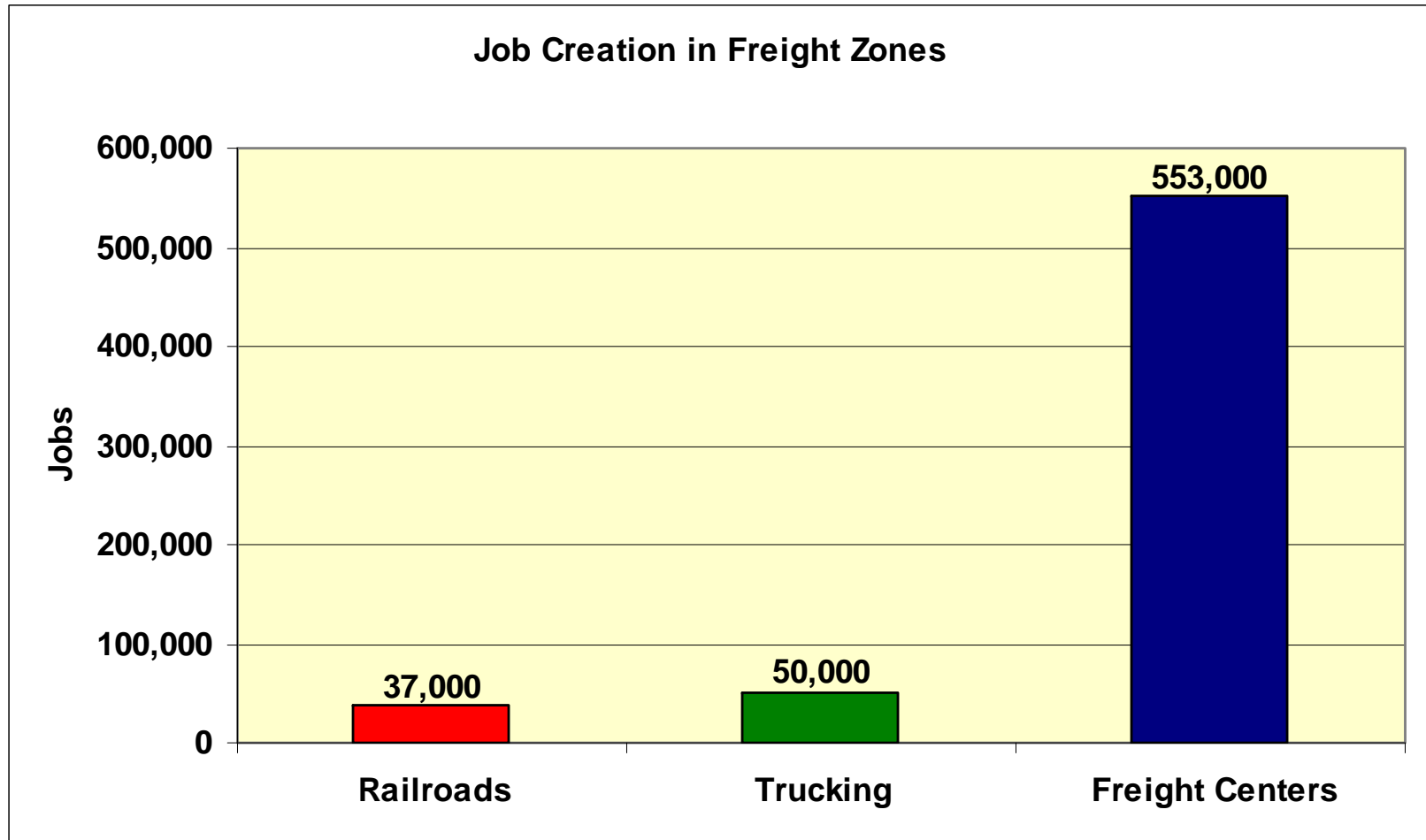

> 3,000 acres of potential COD sites in the Green TIME Zone

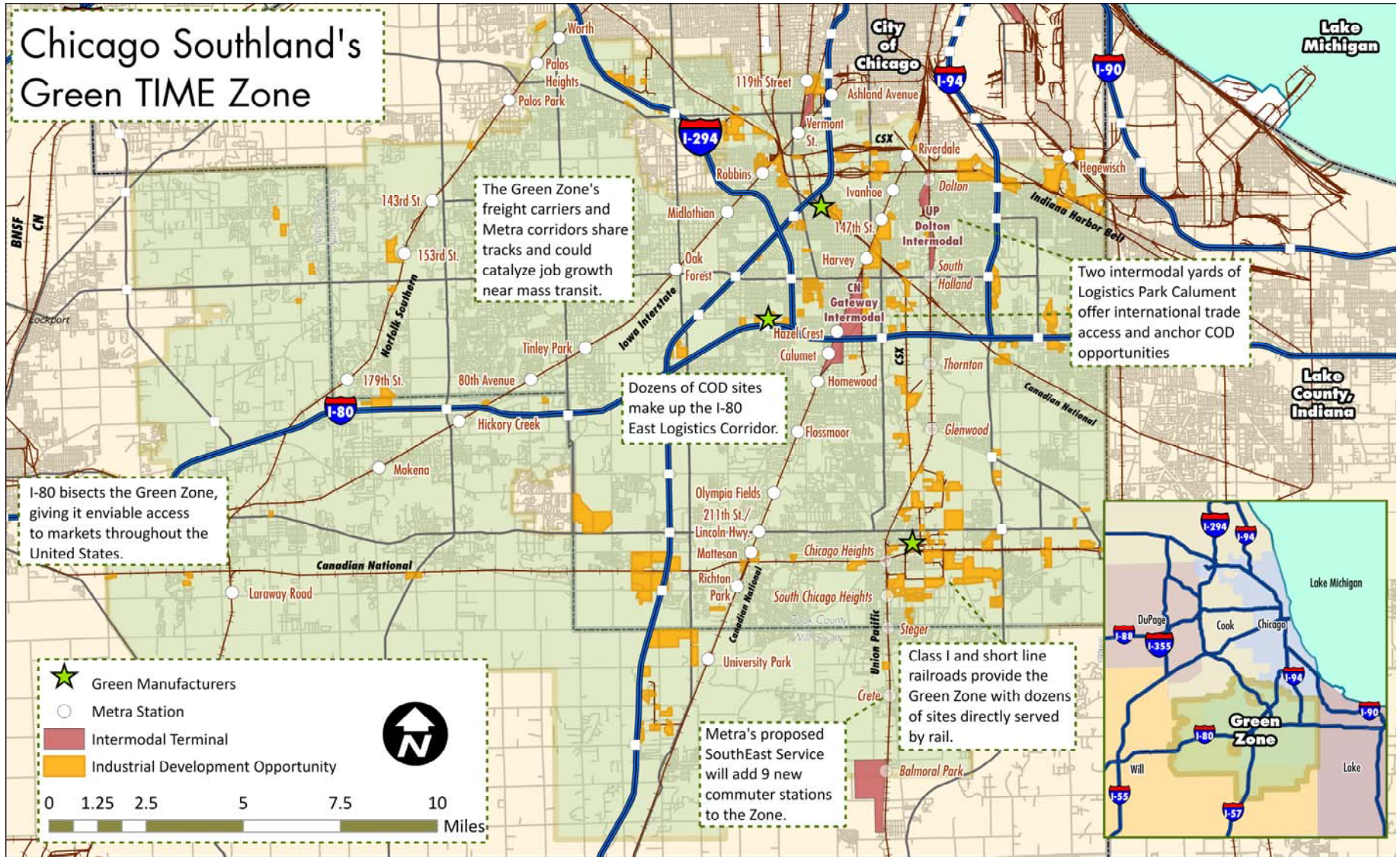

> 1,000 of acres in Potential COD sites in the inner ring of Logistics Park Calumet, industrial core of the Green TIME Zone

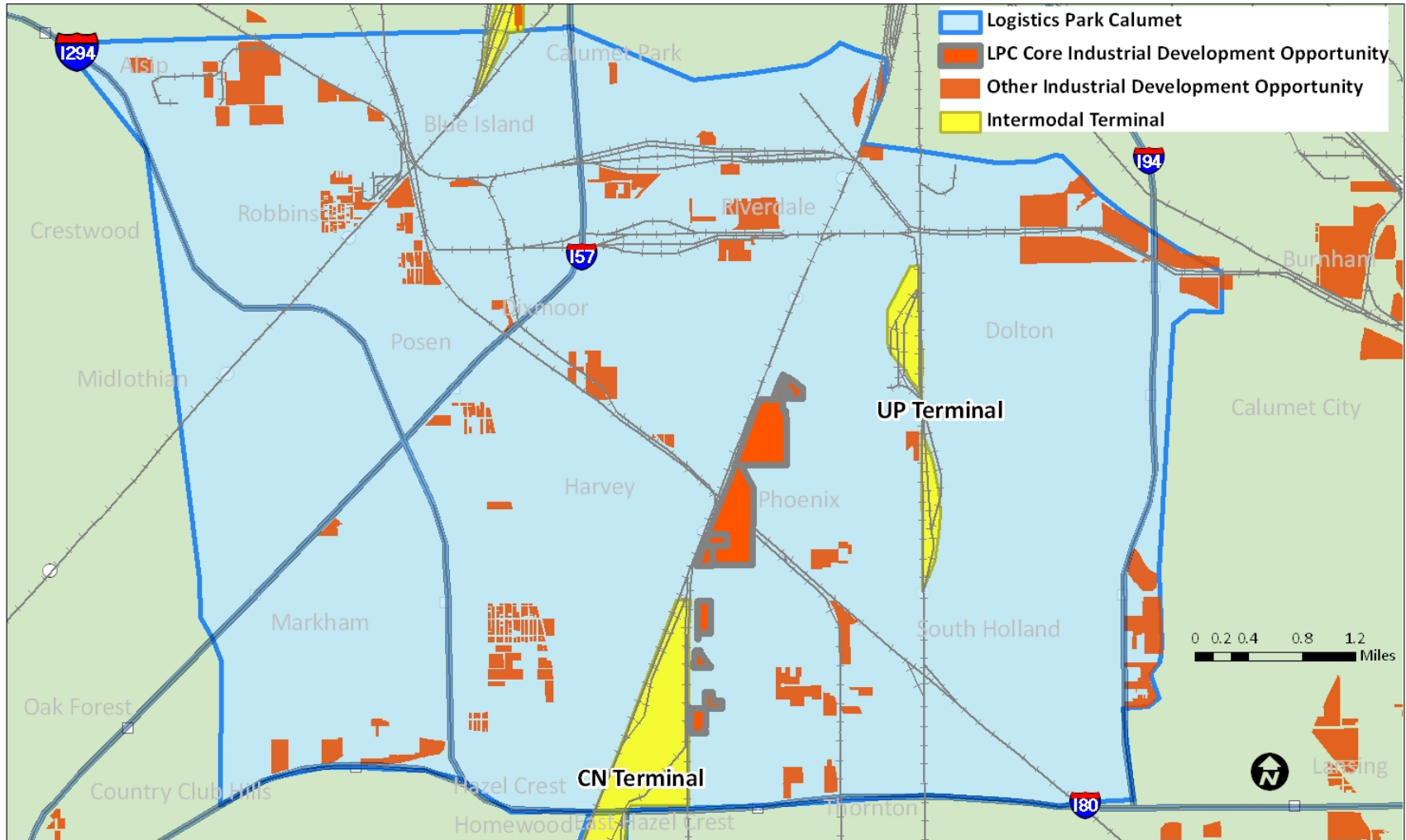

Net Benefits

- 13,451 in potential new jobs
- \$2.3 billion in new income
- \$133 million in local tax revenue over ten year period
- 2.43 million truck miles avoided per year
- \$28.3 million in additional net income
- 192 million vehicle miles avoided
- 110,307 metric tons of CO2 emissions avoided per year

GTZ Potential Depends on Green Manufacturing



Calumet Manufacturing Center

- Regional Supplier Program
- Production Capacity Support
- R & D, Prototype Development
- Alternative Energy Production
- Workforce Development
- International Marketing, New Green Business Attraction

National Railway Equipment Company Innovations

N-Viromotive Product Line:

- >80% Reduction in NOX & PMs
- 40% to 70% Gain in Fuel Efficiency
- Ultra Quiet Locomotive Operations

High Speed Rail Locomotive
Under Development



Windmill Component Suppliers: Funk Linko, LB Steel and Tempest





Advanced Mid-Size Wind Turbine Technology





The Tempest Ariel™ Series Wind Turbines

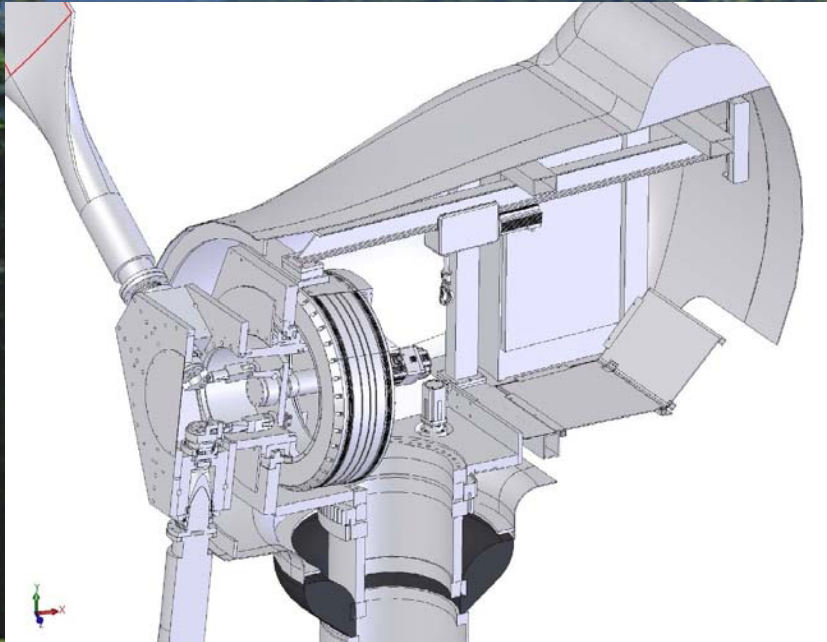

- ✓ EFFICIENT
- ✓ COMPACT
- ✓ QUIET
- ✓ RELIABLE

Patent pending # 61317-227

Sustainable Wind Turbine Technologies

for Sustainable Job Creation in Illinois

and the United States



Proudly
Designed & Manufactured
in USA



Mi-Jack Green Innovations

- Pathfinder Terminal Management System
- Cargo Blanket
- Electric Intermodal Lift Cranes
- Lithium Battery Exploration



Green Manufacturing Requirements

- Capital Equipment Investments
- Research & Development:
 - Prototype Development
 - Local Innovations of New Technologies
- New Business Locations in the Green TIME Zone Cluster

Integrated Green Opportunities

